

TILT BEAM SENSOR

Description

Tilt beam sensors consist of aluminum metal bars of 1, 2 or 3 meters long on which is mounted a high-sensitivity inclinometric electrolytic-type sensor. They are typically installed in a series, so that the end of a bar coincides with the beginning of the next, until it covers the required distance. The differential movements of the structure cause a different rotation of the bars and this shows the movements or differential settlements of the structure to be monitored.



Please specify

CODE	PRODUCT DESCRIPTION
ELB-101	Tilt beam sensor, FS +/-1° (output 0-5 Volt)
ELB-210	Aluminium beam lenght 1 m
ELB-220	Aluminium beam lenght 2 m
ELB-230	Aluminium beam lenght 3 m
ELB-500	Accessories for vertical mounting

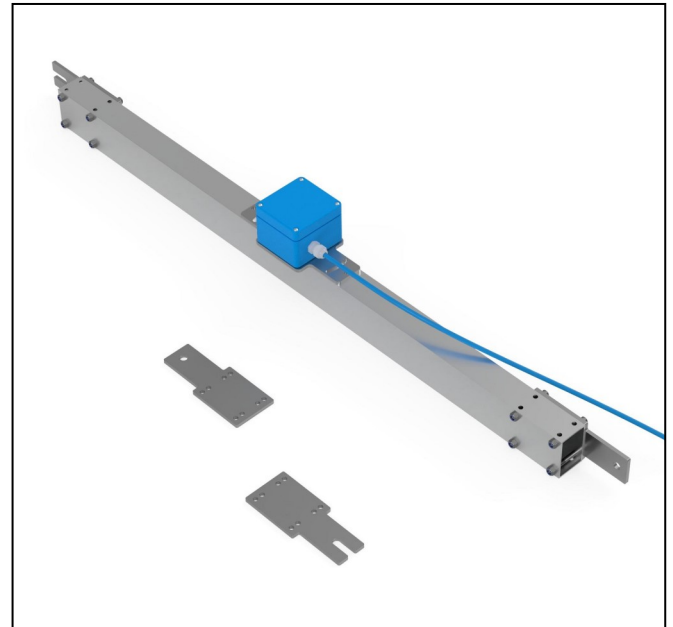

Technical specifications

Sensor type	Uniaxial and biaxial electrolytic
Range	+/- 3°
Linear range	+/- 1°
Linearity (+/- 1°)	<3%
Repeteability	+/- 0.001°
Resolution	+/- 0.0003°
Long term stability	<0.001°
Operating temp.	-20...+50 °C
Power	3.3-5.0 Vdc stabilized
Signal output	voltage (da 0 a max 5 V)
Case material	aluminium
Class of protection	IP67

For further information:

Gestecno s.r.l.

Loc. Lanciano, 22 - 62022 Castelraimondo (MC) - Italy
Tel/fax: (+39) 0737.642174 - P. IVA 01137480438
e-mail: info@gestecno.it - WEB: www.gestecno.it